



Minipack-torre S.p.A.
Via Provinciale, 54 - 24044 Dalmine (BG) - Italy
Tel. (035) 563525 – Fax (035) 564945
E-mail: info@minipack-torre.it
<http://www.minipack-torre.it>



minipack FM76N

Catalogo ricambi

(Valido dalla matricola nr. 7221 del 03.1990 fino al nr. 9700 del 10.1993)

Spare parts catalogue

(Valid from serial number 7221 dated 03.1990 at to 9700 dated 10.1993)

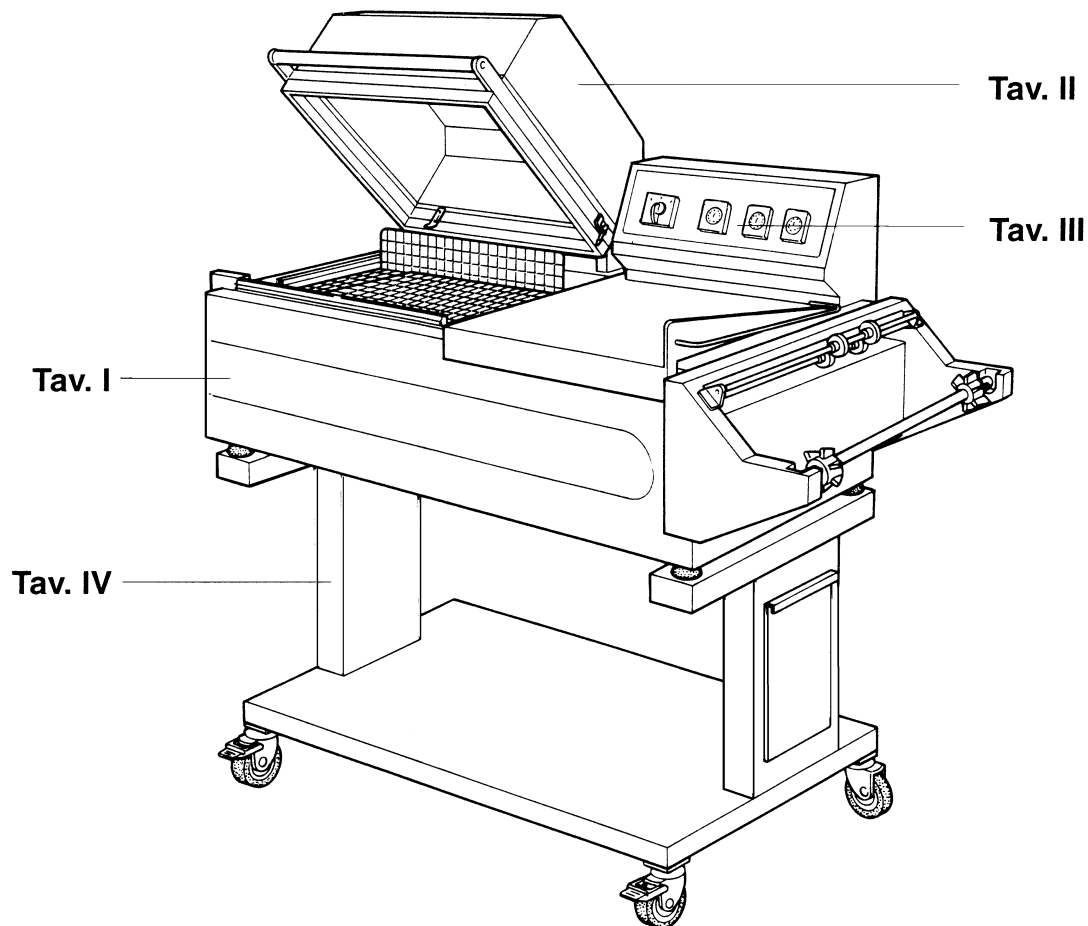

**CONSULTARE ATTENTAMENTE QUESTO CATALOGO PRIMA DI ORDINARE PEZZI DI RICAMBIO
CAREFULLY READ THIS CATALOG BEFORE ORDERING SPARE PARTS**

INDICE / INDEX

<i>ESPLOSO MACCHINA TAVOLA I / SCHEME I MACHINE DETAIL DRAWING</i>	<i>pag./page 2</i>
<i>ESPLOSO MACCHINA TAVOLA II / SCHEME II MACHINE DETAIL DRAWING</i>	<i>pag./page 3</i>
<i>ESPLOSO MACCHINA TAVOLA II Bis / SCHEME II Bis MACHINE DETAIL DRAWING</i>	<i>pag./page 4</i>
<i>ESPLOSO MACCHINA TAVOLA III / SCHEME III MACHINE DETAIL DRAWING</i>	<i>pag./page 5</i>
<i>ESPLOSO MACCHINA TAVOLA IV / SCHEME IV MACHINE DETAIL DRAWING</i>	<i>pag./page 6</i>
<i>ESPLOSO MACCHINA TAVOLA IV Bis / SCHEME IV Bis MACHINE DETAIL DRAWING</i>	<i>pag./page 7</i>
<i>SCHEMA ELETTRICO / WIRING DIAGRAM</i>	<i>pag./page 8</i>

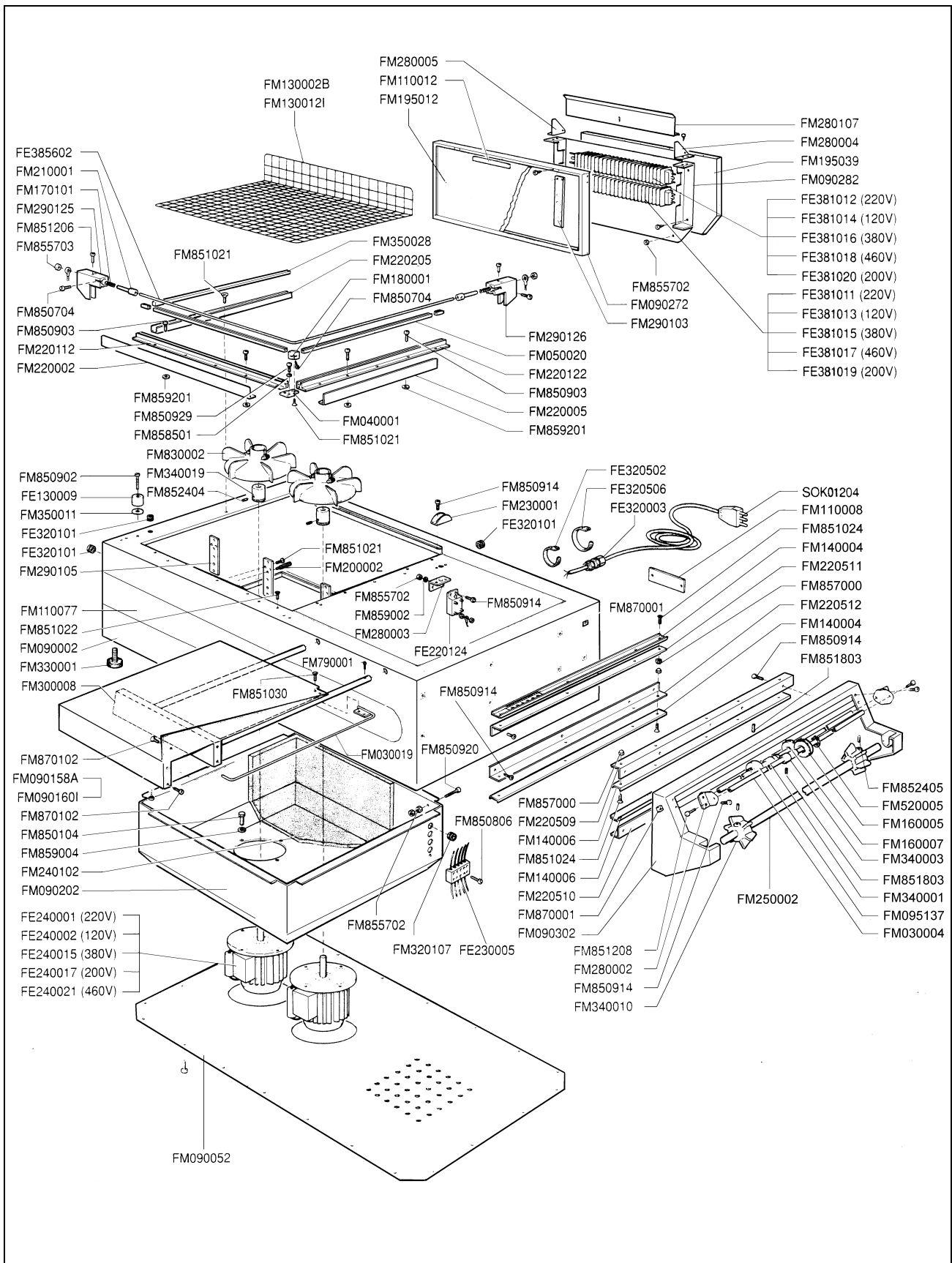

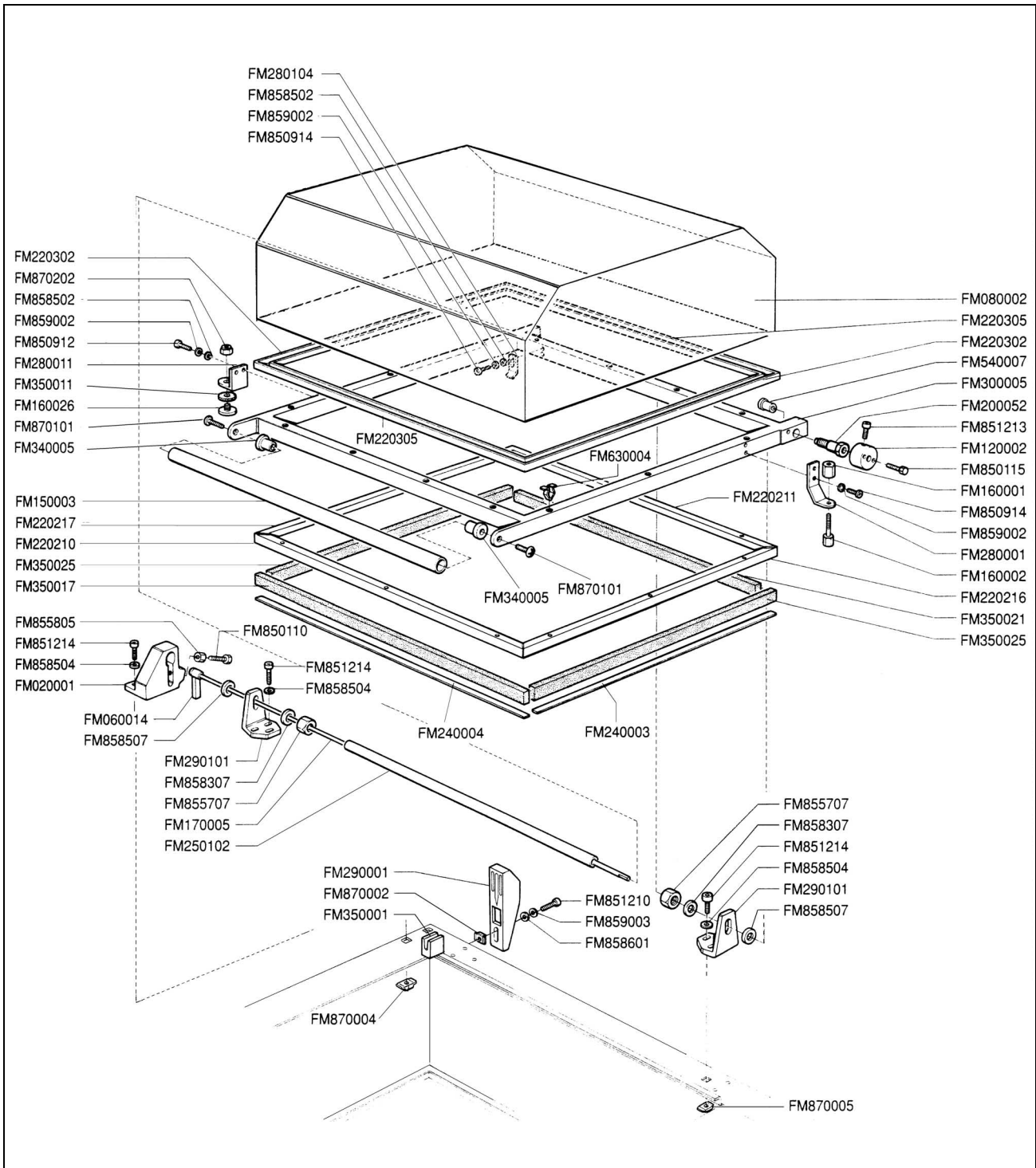

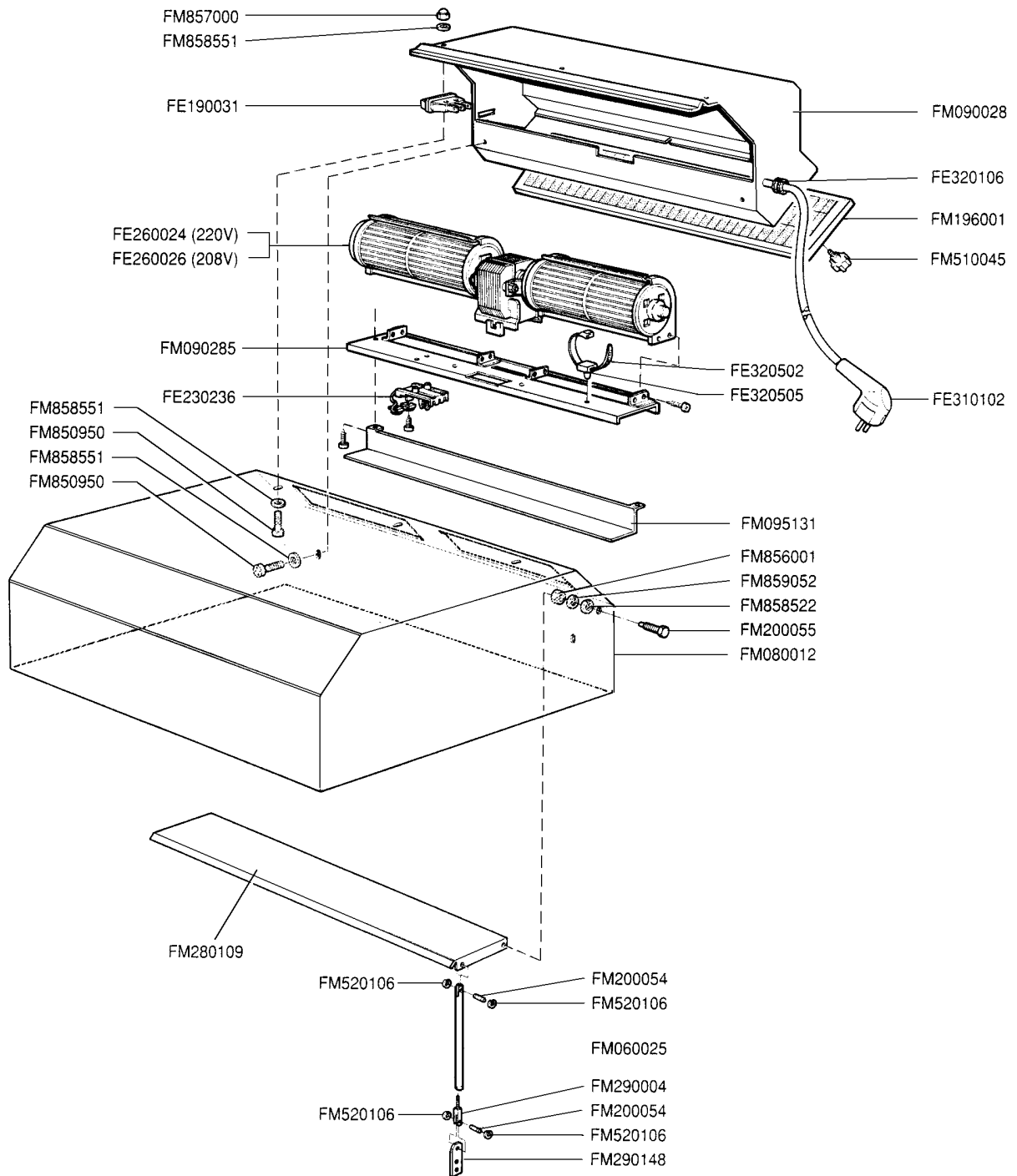

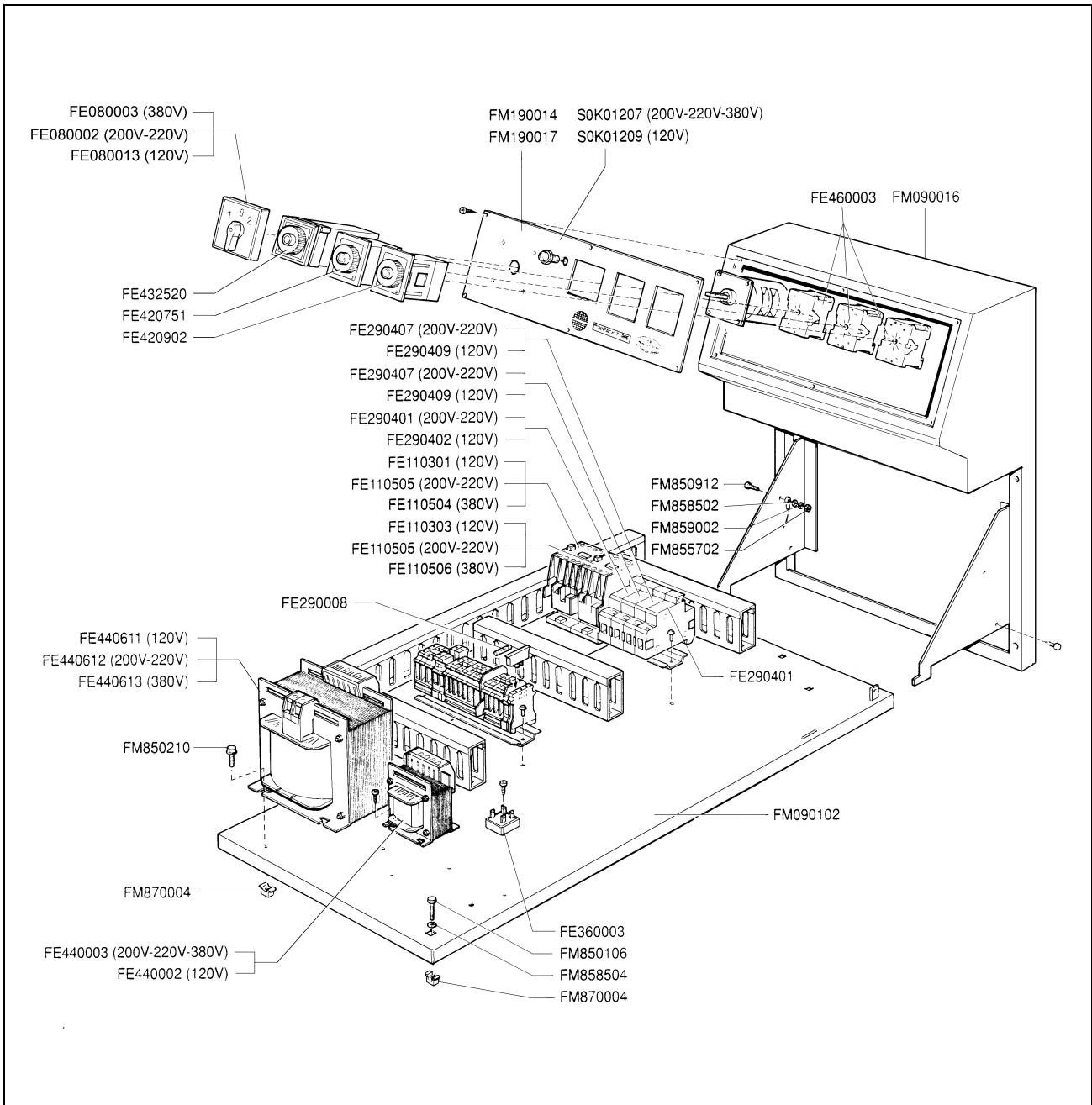

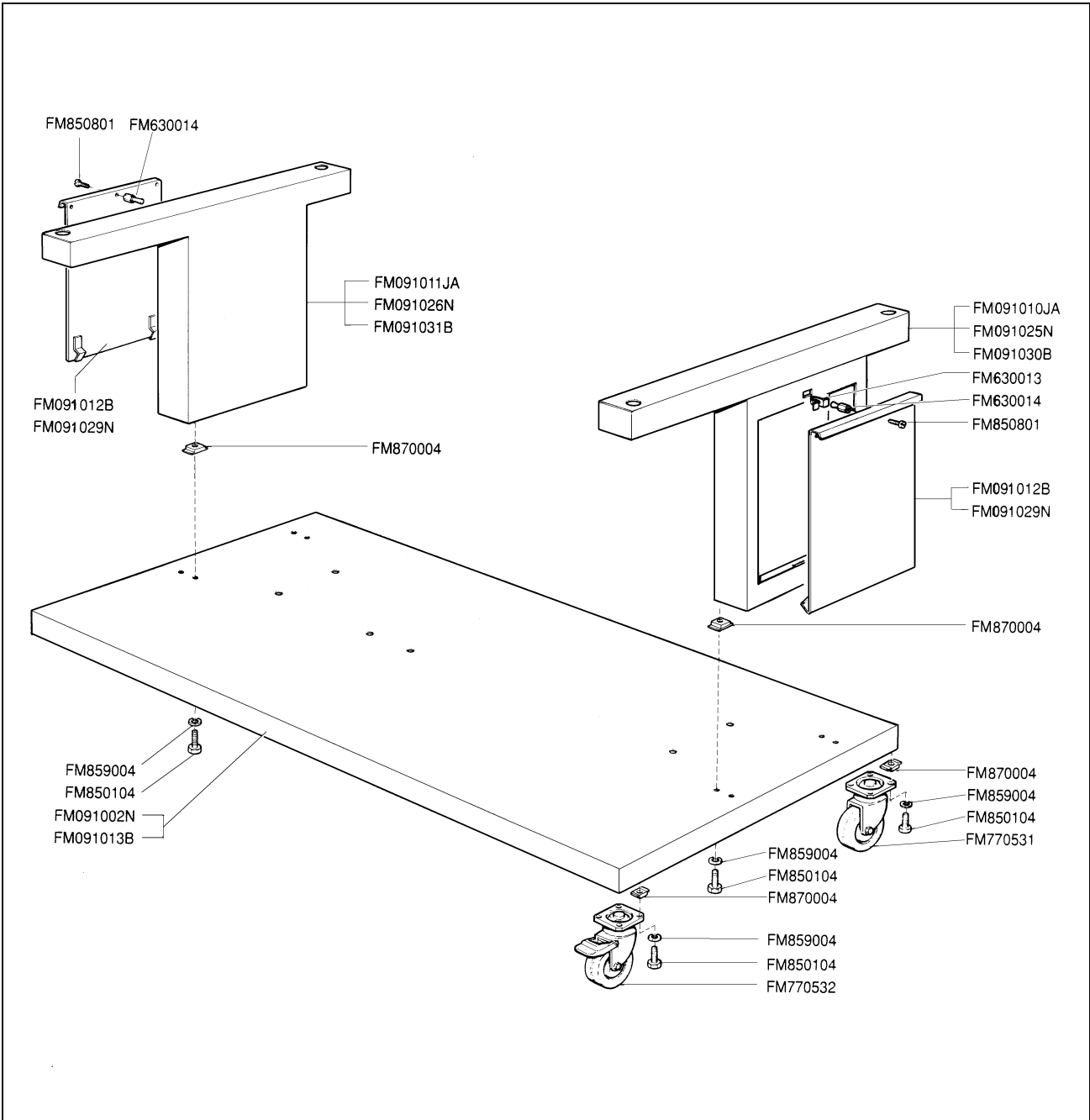

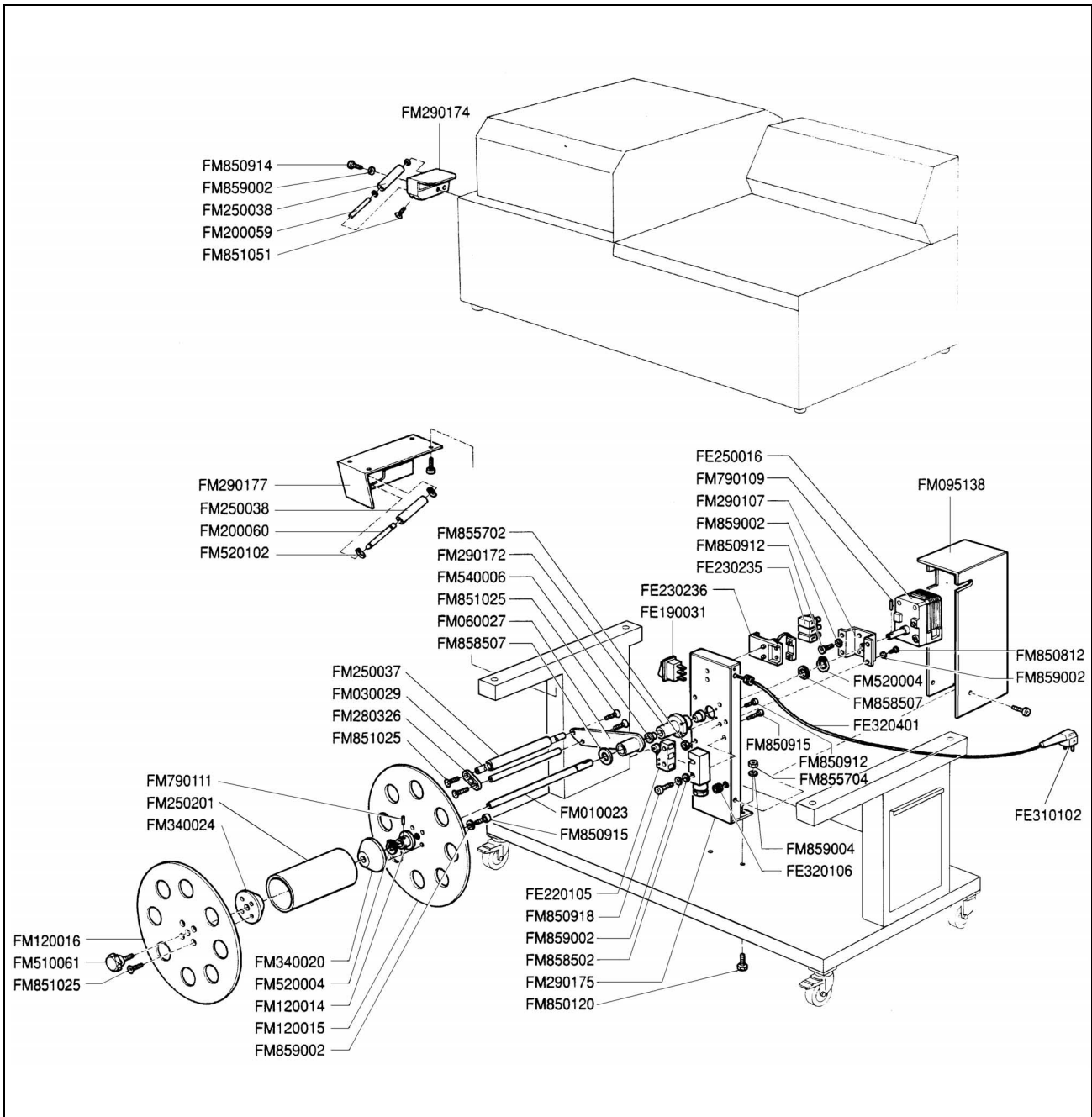

SCHEMA ELETTRICO / WIRING DIAGRAM

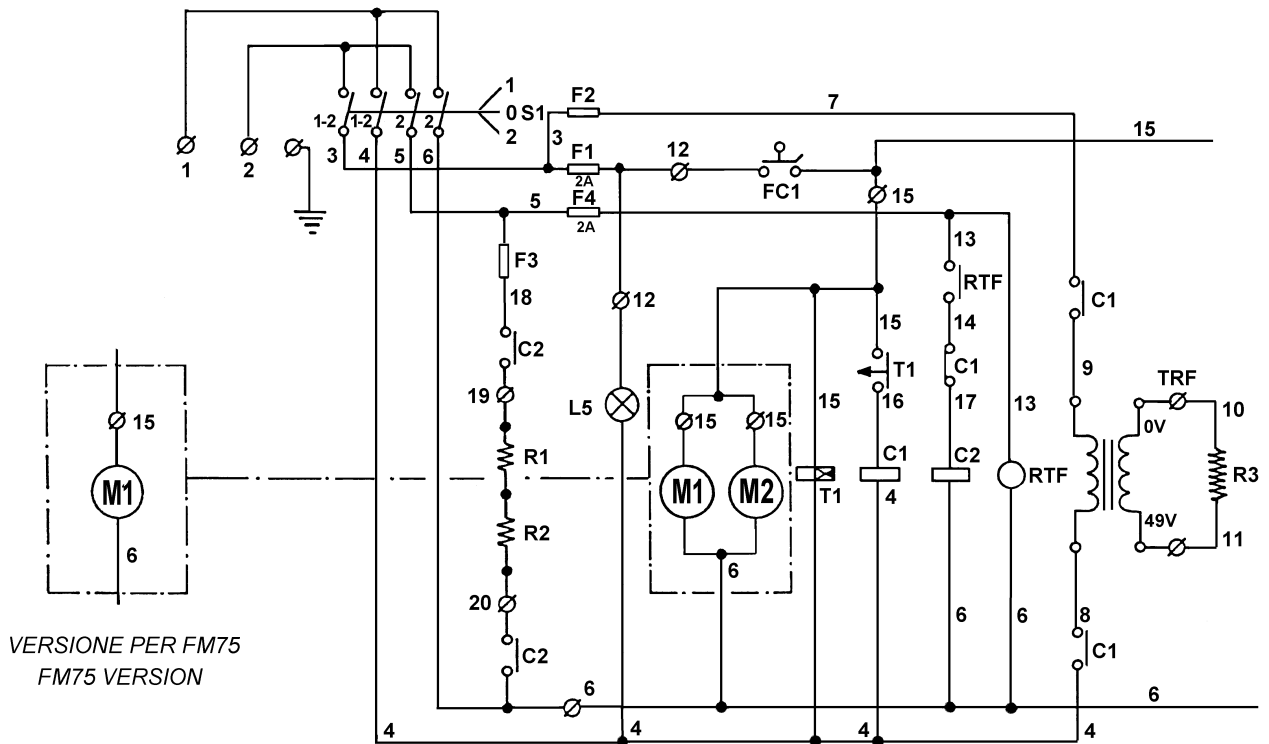

1 2 10 11 19 20 6 12 15 15 FM 75

1 2 10 11 19 20 6 6 12 15 15 15 FM 76

MINIPACK FM 75 FM76 220V. 50 HZ

S1	Selettore ciclo	Cycle selector
C1	Contattore trasformatore taglio	Cutting blade contactor
C2	Contattore resistenze	Heaters contactor
RTF	Termoregolatore	Thermoregulator
T1	Temporizzatore taglio	Cutting blade timer
LS	Spie tensione macchina	Light
TRF	Trasformatore taglio	Cutting blade transformer
FC1	Finecorsa ciclo macchina	Machine control limit
M1	Motore ventilazione 1	Fan motor 1
M2	Motore ventilazione 2 (solo per FM76)	Fan motor 2 (only for FM76)
R1	Resistenza	Heater
R2	Resistenza	Heater
R3	Resistenza di taglio	Cutting resistance
F1	Fusibile 2A	Fuse 2A
F2	Fusibile 16A	Fuse 16A
F3	Fusibile 16A	Fuse 16A
F4	Fusibile 2A	Fuse 2A



Minipack-torre S.p.A.

Via Provinciale, 54 - 24044 DALMINE (BG) - ITALY

Tel. (035) 563525 – Fax (035) 564945

E-mail: info@minipack-torre.it

Internet: www.minipack-torre.it